

INSTALLATION INSTRUCTIONS

FIRE AND DRAFT SEALER™

SEALING PENETRATING ITEMS THROUGH CONCRETE AND BRICK MASONRY (INTERIOR SURFACES ONLY)

Step 1:	All surfaces should be clean, sound, and free of loose debris. Moist or damp surfaces are acceptable.
Step 2:	(Recommended) To minimize the amount of FIRE and DRAFT SEALER™ required to fill the void the area between the penetrating item(s) and the clearance opening should be firmly packed with a filler material (mineral wool) leaving $\frac{3}{4}$ inch for FIRE and DRAFT SEALER™.
Step 3:	Apply FIRE and DRAFT SEALER™ $\frac{3}{4}$ inch deep around the penetrating item(s) and firmly against the concrete or brick surface filling the void. The face surface of the installed FIRE and DRAFT SEALER™ may be trowelled flush with the surface of the wall.
Note:	FIRE and DRAFT SEALER™ can be sanded and painted with any type of paint. Allow FIRE and DRAFT SEALER™ to fully cure before sanding or painting.

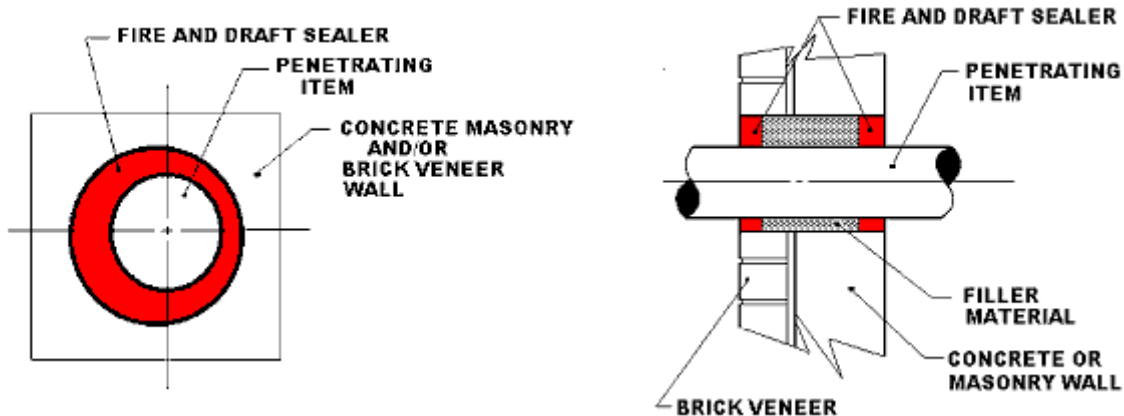

**UL 723 (ASTM-E84) FLAME INDEX ZERO SMOKE INDEX ZERO
ASTM-E136 NON-COMBUSTIBLE**

SEALING PENETRATING ITEMS THROUGH CONCRETE FLOORS AND CEILINGS

VOIDS ONE INCH OR LESS IN WIDTH

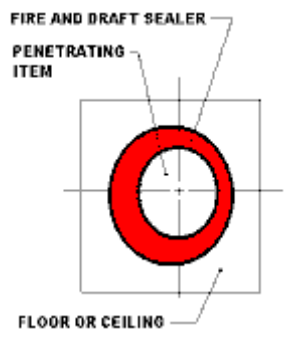
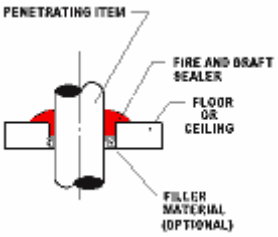
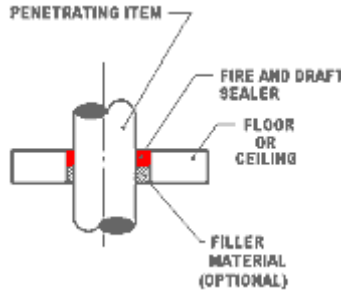
	<p>Step 1:</p>	<p>All surfaces should be clean, sound, free of debris. Moist or damp surfaces are acceptable. (Optional) If a filler material (mineral wool) is used to reduce the amount of FIRE and DRAFT SEALER™ required to fill the void, the filler material should be firmly packed around the penetrating item(s) and against the member allowing ¾ inch for FIRE and DRAFT SEALER™</p>
	<p>Step 2:</p>	<p>Apply FIRE and DRAFT SEALER™ ¾ inch deep around the penetrating item(s) and firmly against the structural member filling the void. The surface of the installed FIRE and DRAFT SEALER™ may be trowelled flush with the surface of the floor or ceiling.</p>
	<p>Note:</p>	<p>FIRE and DRAFT SEALER™ can be sanded and painted with any type of paint. Allow FIRE and DRAFT SEALER™ to fully cure before sanding or painting.</p>
<p>USING A BACKING PLATE FOR ADDED SUPPORT RECOMMENDED WHEN THE WIDTH OF THE VOID EXCEEDS ONE INCH</p>		
	<p>Step 1:</p>	<p>The backing plate should be cut to fit around the penetration item(s) and extend beyond the clearance opening to allow for adequate securing to the structural member using mechanical fasteners. (Optional) A filler material (mineral wool) may be used to reduce the amount of FIRE and DRAFT SEALER™ required to fill the void. The filler material should be firmly packed around the penetrating item(s) and against structural member leaving ¾ inch for FIRE and DRAFT SEALER™.</p>
	<p>Step 2:</p>	<p>All surfaces should be clean, sound, free of debris. Moist or damp surfaces are acceptable.</p>
	<p>Step 3:</p>	<p>Apply FIRE and DRAFT SEALER™ ¾ inch deep around the penetrating item(s) and firmly against the structural member filling the void. The surface of the installed FIRE and DRAFT SEALER™, may be trowelled flush with the surface of the floor or ceiling.</p>
	<p>Note:</p>	<p>FIRE and DRAFT SEALER™ can be sanded and painted with any type of paint. Allow FIRE and DRAFT SEALER™ to fully cure before sanding or painting.</p>

**UL 723 (ASTM-E84) FLAME INDEX ZERO SMOKE INDEX ZERO
ASTM-E136 NON-COMBUSTIBLE**

SEALING PENETRATING ITEMS THROUGH INSULATED GYPSUM WALL ASSEMBLIES

INSULATED GYPSUM BOARD WALL ASSEMBLIES

Step 1:	All surfaces should be clean, dry, and free of loose debris and dust.
Step 2:	Apply FIRE and DRAFT SEALER™ $\frac{3}{4}$ inch deep around the penetrating item(s) and firmly against the gypsum board surfaces filling the void. FIRE and DRAFT SEALER™ should be installed beyond the interior surface of the gypsum board wall assembly to assure a firm anchor. The surface of the installed FIRE and DRAFT SEALER™ may be trowelled flush with the surface of gypsum board.
Note:	FIRE and DRAFT SEALER™ can be sanded and painted with any type of paint. Allow FIRE and DRAFT SEALER™ to fully cure before sanding or painting.

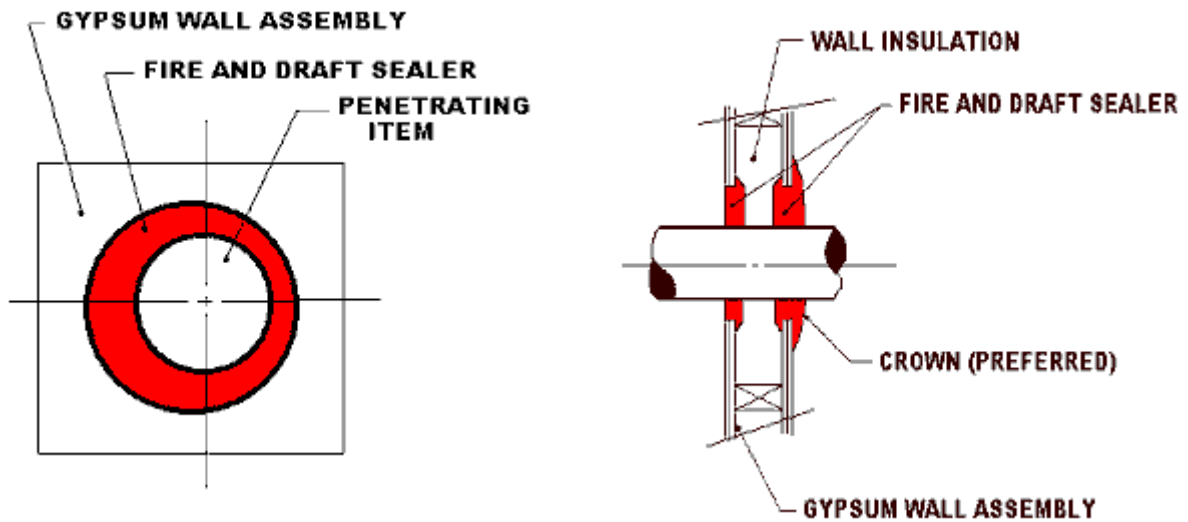

**UL 723 (ASTM-E84) FLAME INDEX ZERO SMOKE INDEX ZERO
ASTM-E136 NON-COMBUSTIBLE**

SEALING PENETRATING ITEMS THROUGH UNINSULATED GYPSUM WALL ASSEMBLIES

UNINSULATED GYPSUM BOARD WALL ASSEMBLIES

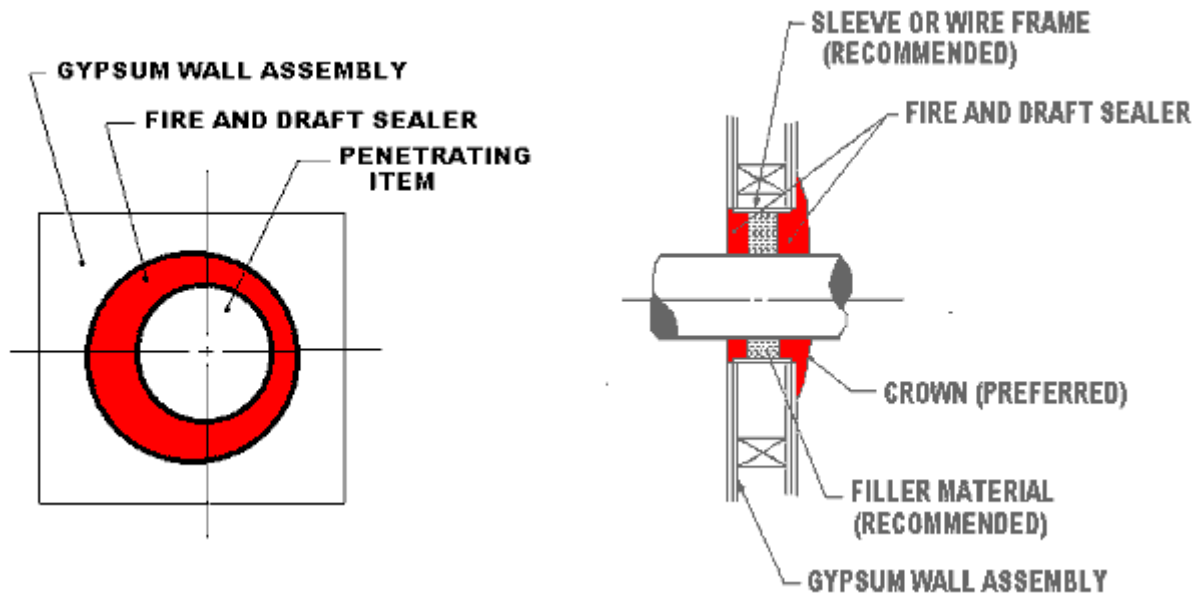

Step 1:	(Recommended) Place a sleeve, or wire frame, into the clearance hole spanning the gypsum board wall assembly. Pack the area around the penetrating item(s) and the sleeve, or wire frame, with a filler material (mineral wool) leaving $\frac{3}{4}$ inch for FIRE and DRAFT SEALER™.
Step 2:	All surfaces should be clean, dry, and free of loose debris and dust.
Step 3:	Apply FIRE and DRAFT SEALER™ $\frac{3}{4}$ inch deep around the penetrating item(s) and firmly against the gypsum board filling the void. The surface of the installed FIRE and DRAFT SEALER™ may be trowelled flush with the surface of the gypsum board.
Note:	FIRE and DRAFT SEALER™ can be sanded and painted with any type of paint. Allow FIRE and DRAFT SEALER™ to fully cure before sanding or painting.



**UL 723 (ASTM-E84) FLAME INDEX ZERO SMOKE INDEX ZERO
ASTM-E136 NON-COMBUSTIBLE**

SEALING PENETRATING ITEMS THROUGH WOOD FLOORS AND CEILINGS

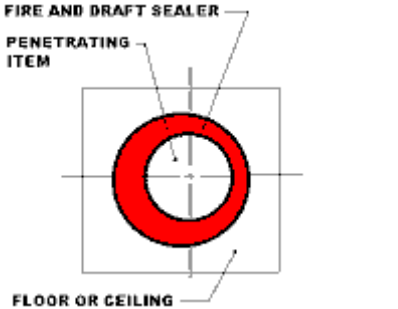
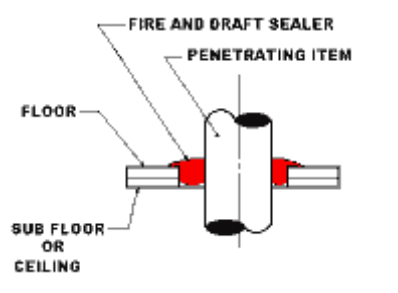
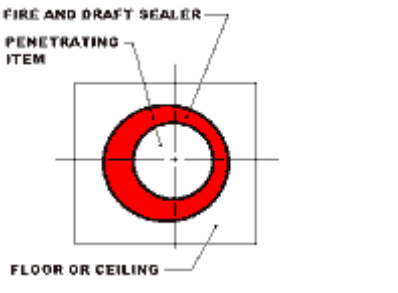
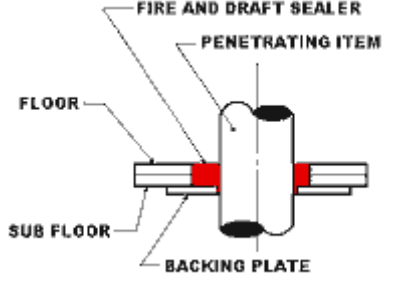
VOIDS ONE INCH OR LESS IN WIDTH

	<p>Step 1:</p>	<p>All surfaces should be clean, sound, free of debris. Moist or damp surfaces are acceptable.</p>
	<p>Step 2:</p>	<p>Apply FIRE and DRAFT SEALER™ ¾ inch deep around the penetrating item(s) and firmly against the structural members filling the void and building a slight crown around the penetrating item(s) and over the edges of the structural members.</p>
	<p>IF USING A BACKING PLATE FOR ADDED SUPPORT (Recommended when the width of the void exceeds one inch)</p>	
	<p>Step 1:</p>	<p>The backing plate should be cut to fit around the penetration item(s) and extend beyond the clearance opening to allow for adequate securing to the structural members using mechanical fasteners.</p>
	<p>Step 2:</p>	<p>All surfaces should be clean, sound, and free of debris. Moist surfaces are acceptable.</p>
	<p>Step 3:</p>	<p>Apply FIRE and DRAFT SEALER™ ¾ inch deep around the penetrating item(s) and firmly against the structural members filling the void. The surface of the installed FIRE and DRAFT SEALER™ may be trowelled flush with the surface of the floor or ceiling.</p>
	<p>Note:</p>	<p>FIRE and DRAFT SEALER™ can be sanded and painted with any type of paint. Allow FIRE and DRAFT SEALER™ to fully cure before sanding or painting.</p>

**UL 723 (ASTM-E84) FLAME INDEX ZERO SMOKE INDEX ZERO
ASTM-E136 NON-COMBUSTIBLE**

SEALING SCD 40 PVC 6" OR LESS THROUGH WOOD FLOORS AND CEILINGS

VOIDS ONE INCH OR LESS IN WIDTH

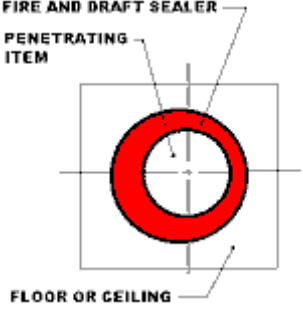
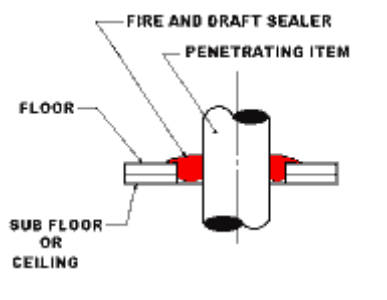
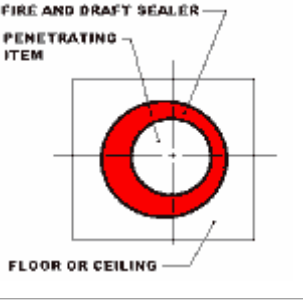
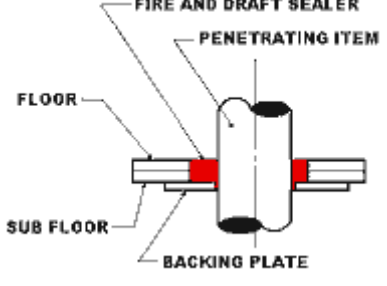
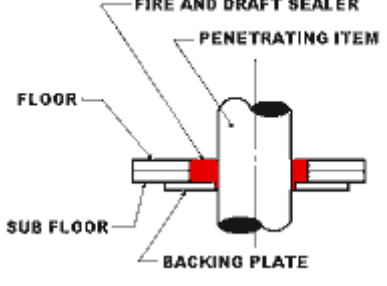
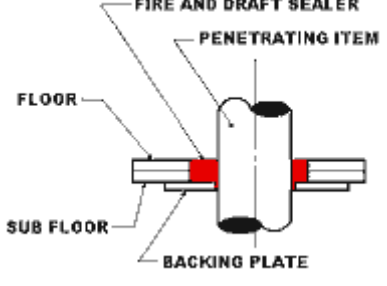
	<p>Step 1:</p>	<p>All surfaces should be clean, sound, free of debris. Moist or damp surfaces are acceptable.</p>
	<p>IF USING A BACKING PLATE FOR ADDED SUPPORT (Recommended when the width of the void exceeds one inch)</p>	
	<p>Step 1:</p>	<p>The backing plate should be cut to fit around the penetration item(s) and extend beyond the clearance opening to allow for adequate securing to the structural members using mechanical fasteners.</p>
	<p>Step 2:</p>	<p>All surfaces should be clean, sound, and free of debris. Moist surfaces are acceptable.</p>
	<p>Step 3:</p>	<p>Apply FIRE and DRAFT SEALER™ ¾ inch deep around the penetrating item(s) and firmly against the structural members filling the void. The surface of the installed FIRE and DRAFT SEALER™ may be trowelled flush with the surface of the floor or ceiling.</p>
	<p>Note:</p>	<p>FIRE and DRAFT SEALER™ can be sanded and painted with any type of paint. Allow FIRE and DRAFT SEALER™ to fully cure before sanding or painting.</p>

**UL 723 (ASTM-E84) FLAME INDEX ZERO SMOKE INDEX ZERO
ASTM-E136 NON-COMBUSTIBLE**

SEALING PENETRATING ITEMS THROUGH WOOD STUDS, JOISTS AND RAFTERS

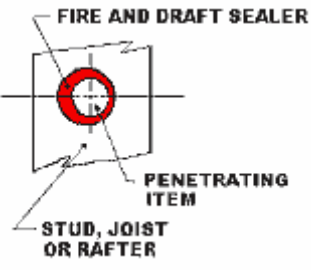
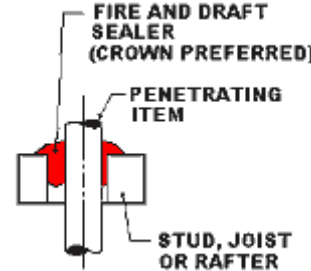
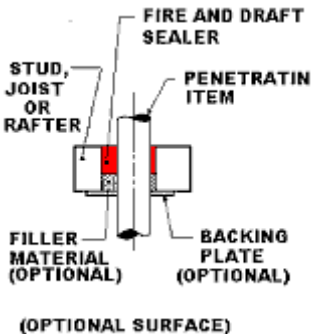
	<p>Step 1:</p>	<p>All surfaces should be clean, free of loose debris. Moist or damp surfaces are acceptable.</p>
	<p>Step 2:</p>	<p>Apply FIRE and DRAFT SEALER™ ¾ inch deep into the void and firmly against the structural member and around the penetrating item(s) building a slight crown around the penetrating item(s) and over the edges of the structural member (at least on one surface).</p>
	<p>IF A BACKING PLATE IS USED FOR ADDED SUPPORT. (Recommended when the width of the void exceeds one inch)</p>	
	<p>Step 1:</p>	<p>The backing plate should be cut to fit around the penetration item(s) and extend beyond the clearance opening to allow for adequate securing to the structural members using mechanical fasteners. (Optional) If a filler material (mineral wool) is used to reduce the amount of FIRE and DRAFT SEALER™ required to fill the void, the filler material should be firmly packed around the penetrating item(s) and against the structural member allowing ¾ inch for FIRE and DRAFT SEALER™.</p>
	<p>Step 3:</p>	<p>Apply FIRE and DRAFT SEALER™ ¾ inch deep around the penetrating item(s) and firmly against the structural members filling the void. The surface of the installed FIRE and DRAFT SEALER™ may be trowelled flush with the surface of the floor or ceiling.</p>
	<p>Note:</p>	<p>FIRE and DRAFT SEALER™ can be sanded and painted with any type of paint. Allow FIRE and DRAFT SEALER™ to fully cure before sanding or painting.</p>

**UL 723 (ASTM-E84) FLAME INDEX ZERO SMOKE INDEX ZERO
ASTM-E136 NON-COMBUSTIBLE**

SEALING SCD 40 PVC 6" OR LESS THROUGH WOOD STUDS, JOISTS AND RAFTERS

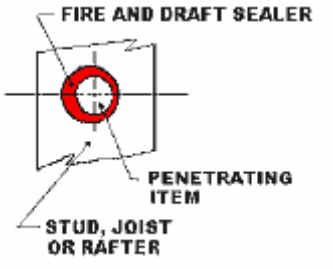
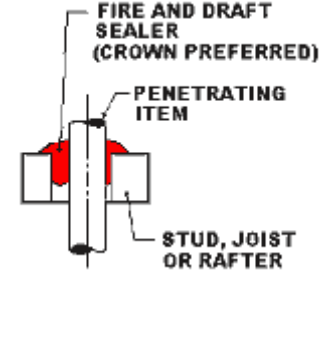
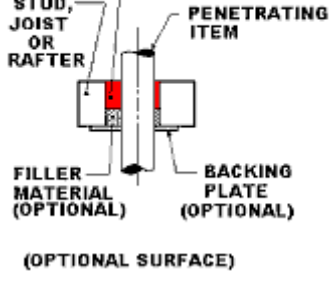
 <p style="text-align: center;">FIRE AND DRAFT SEALER</p> <p style="text-align: center;">PENETRATING ITEM</p> <p style="text-align: center;">STUD, JOIST OR RAFTER</p>	<p>Step 1:</p>	<p>All surfaces should be clean, free of loose debris. Moist or damp surfaces are acceptable.</p>
	<p>Step 2:</p>	<p>Apply FIRE and DRAFT SEALER™ ¾ inch deep into the void and firmly against the structural member and around the penetrating item(s) building a slight crown around the penetrating item(s) and over the edges of the structural member (at least on one surface).</p>
 <p style="text-align: center;">FIRE AND DRAFT SEALER (CROWN PREFERRED)</p> <p style="text-align: center;">PENETRATING ITEM</p> <p style="text-align: center;">STUD, JOIST OR RAFTER</p>	<p>IF A BACKING PLATE IS USED FOR ADDED SUPPORT. (Recommended when the width of the void exceeds one inch)</p>	
	<p>Step 1:</p>	<p>The backing plate should be cut to fit around the penetration item(s) and extend beyond the clearance opening to allow for adequate securing to the structural members using mechanical fasteners. (Optional) If a filler material (mineral wool) is used to reduce the amount of FIRE and DRAFT SEALER™ required to fill the void, the filler material should be firmly packed around the penetrating item(s) and against the structural member allowing ¾ inch for FIRE and DRAFT SEALER™.</p>
 <p style="text-align: center;">FIRE AND DRAFT SEALER</p> <p style="text-align: center;">PENETRATING ITEM</p> <p style="text-align: center;">STUD, JOIST OR RAFTER</p> <p style="text-align: center;">FILLER MATERIAL (OPTIONAL)</p> <p style="text-align: center;">BACKING PLATE (OPTIONAL)</p> <p style="text-align: center;">(OPTIONAL SURFACE)</p>	<p>Step 2:</p>	<p>All surfaces should be clean, sound, and free of debris. Moist surfaces are acceptable.</p>
	<p>Step 3:</p>	<p>Apply FIRE and DRAFT SEALER™ ¾ inch deep around the penetrating item(s) and firmly against the structural members filling the void. The surface of the installed FIRE and DRAFT SEALER™ may be trowelled flush with the surface of the floor or ceiling.</p>
	<p>Note:</p>	<p>FIRE and DRAFT SEALER™ can be sanded and painted with any type of paint. Allow FIRE and DRAFT SEALER™ to fully cure before sanding or painting.</p>

**UL 723 (ASTM-E84) FLAME INDEX ZERO SMOKE INDEX ZERO
ASTM-E136 NON-COMBUSTIBLE**

SEALING PENETRATING ITEMS THROUGH METAL STUDS AND RAFTERS

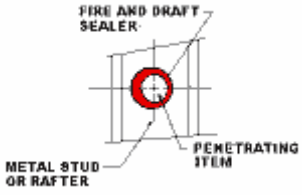
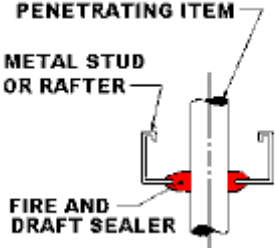
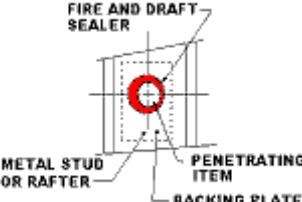
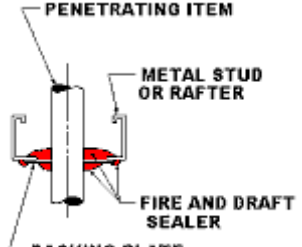
 <p style="font-size: small;">FIRE AND DRAFT SEALER METAL STUD OR RAFTER PENETRATING ITEM</p>	<p>Step 1:</p>	<p>All surfaces should be clean, free of loose debris. Moist or damp surfaces are acceptable.</p>
	<p>Step 2:</p>	<p>Apply FIRE and DRAFT SEALER™ to the entire surface of the penetrating item(s) filling the void and building a slight crown around the penetrating item(s) and over the edges of the structural member on both surfaces.</p>
 <p style="font-size: small;">PENETRATING ITEM METAL STUD OR RAFTER FIRE AND DRAFT SEALER</p>	<p>WHEN THE VOID IN THE STRUCTURAL MEMBER AND THE PENETRATING ITEM(S) EXCEEDS ONE INCH IN WIDTH THE USE OF A BACKING PLATE IS RECOMMENDED.</p>	
	<p>Step 1:</p>	<p>The backing plate should be cut to fit around the penetration item(s) and extend beyond the clearance opening to allow for adequate securing to the structural members using mechanical fasteners.</p>
 <p style="font-size: small;">FIRE AND DRAFT SEALER METAL STUD OR RAFTER PENETRATING ITEM BACKING PLATE</p>	<p>Step 2:</p>	<p>All surfaces should be clean and free of debris.</p>
 <p style="font-size: small;">PENETRATING ITEM METAL STUD OR RAFTER FIRE AND DRAFT SEALER BACKING PLATE</p>	<p>Step 3:</p>	<p>Apply FIRE and DRAFT SEALER™ to the entire surface of the penetrating item(s) and over the backing plate. Apply FIRE and DRAFT SEALER™ to the seam where the backing plate meets the structural member.</p>

**UL 723 (ASTM-E84) FLAME INDEX ZERO SMOKE INDEX ZERO
ASTM-E136 NON-COMBUSTIBLE**